

ParaLens Microscope Attachment: Malaria

Background

It is estimated that 350 to 500 million people each year are infected with malaria, and that over 1 million die annually from the disease.¹ Despite these statistics, malaria is treatable with early diagnosis and the proper use of anti-malarial medicines. To ensure proper diagnosis, the World Health Organization recommends both clinical and parasitological diagnosis of malaria before beginning a course of treatment.²

One of the most effective means of parasitological diagnosis involves the staining of a patient's blood sample with acridine orange, a fluorescent cationic dye.³ The dye bonds with the nucleic acid in malarial parasites, causing them to appear green or red-orange against a dark red blood cell (RBC) background when excited by blue light in a fluorescence microscope. The QBC Malaria Test, manufactured by QBC Diagnostics, takes advantage of these fluorescence phenomena as well as the fact that components of blood separate by density when subjected to centrifugal force. The test uses a precision capillary tube coated with anticoagulants and acridine orange to stain the sample, and a plastic float insert to mechanically expand and thin the buffy coat and upper RBC layer to a few cell layers thick. Typically, fluorescence microscopes are needed to perform acridine orange-based malaria diagnosis, but they are expensive, bulky, and use a dangerous and fragile mercury or xenon lamp as light sources. Because of these limitations, the use of fluorescence microscopy in malarial diagnosis has not been adopted in many parts of the world hardest hit by the disease.

This application note will demonstrate how the ParaLens Microscope Attachment, as developed by QBC Diagnostics, can work with the QBC Malaria Test to offer a solution to this problem. The ParaLens is an attachment that can be used with almost any light microscope, thereby saving precious laboratory resources otherwise lost to implementing unnecessary new equipment. With just the use of an LED light source, the ParaLens can perform fluorescence microscopy comparable to expensive, commercially available microscopes. By reducing the costs and hassles associated with traditional fluorescence microscopes, the ParaLens can place fluorescence microscopy in the hands of more clinicians on the front lines of the battle against malaria.

The ParaLens System

The ParaLens Microscope Attachment (as seen in Figure 1) can be attached to any conventional light microscope with standard Royal Microscopy Society threading (1). (Note: Ring transition adapters are available for non-standard microscopes.) The ParaLens side arm (2) connects to the LED light source. The high intensity LED produces blue light with a wavelength of approximately 410-511 nm. The LED is DC powered and can be run on any wall outlet using the AC to DC converter included in the system, or by one of several other power options with the addition of the optional ParaLens Portability Pack, including a 12 volt battery, solar powered battery pack, or a USB cable.

Inside the ParaLens side arm, light from the LED light source passes first through a focusing lens (3) and then through an excitation filter (4) that allows only light in the 385-480 nm range into the main body of the ParaLens. A dichroic beam splitter (5) redirects the light downward to the specimen. Powerful objective lenses (6) allow for the magnification of the fluorescent light from the specimen. When the light returns to the beam splitter, light with a wavelength of ~510 nm or higher is allowed to pass through. Because the specimen has been treated with acridine orange, malarial parasites images will appear green and/or red-orange and proceed through to the viewer. An emission filter (7) reduces background noise and optimizes the fluorescence signal

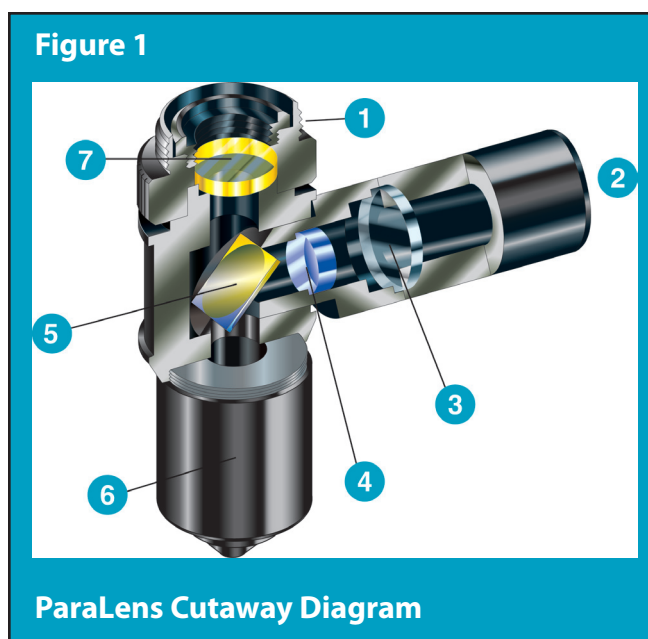

transmitted to the observer.

Reviewing a QBC Malaria Test Set-Up And Focusing

To perform fluorescence microscopy using the ParaLens with the QBC Malaria Test, first prepare and centrifuge the capillary or venous blood sample according to the QBC Malaria Test instructions. Once this is

accomplished, insert the QBC tube into the center groove of the ParaViewer tube holder (as seen in Figure 2). The sealed end should extend over the depressed area of the holder (1), while the open end should pass under the retainer bar and rest against the retainer stop (2). It is important to rest the tube against the retainer stop, as it will prevent movement while the tube is manually turned during examination. The ParaViewer should then be placed on the microscope stage and clamped into place.

Figure 2

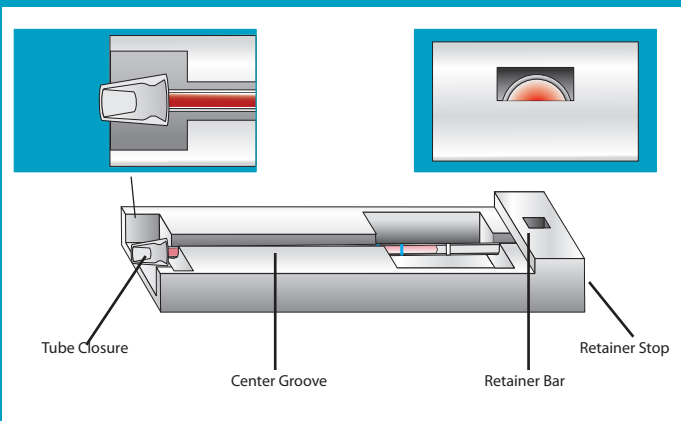

The QBC Malaria Test in the ParaViewer

To bring the tube into focus, apply 2 to 3 drops of fluorescence optical immersion oil to the buffy coat region of the tube. To most easily focus the ParaLens, view the descent of the lens from a side perspective. Attempt to focus the microscope on the buffy coat layer, which should appear slightly fluorescent when properly aligned with the ParaLens. Gradually lower the ParaLens until it touches the oil. There will be a distinct wicking effect when they touch. Now look through the eyepieces, and continue to focus downward. When part of the sample is in focus, gently adjust the Y-axis until most of the surface area is in focus. Once a sufficient percentage of the sample is focused, you should refrain from adjusting the Y-axis again. Instead, manually rotate the tube using the tube closure to see areas at the upper and lower borders of the sample. Turning the tube can cause some of the immersion oil to spread down the sides of the tube, so be sure to add more oil as needed.

Performing a Malaria Test

To begin searching for malaria parasites, slide the field-of-view along the X-axis to the interface of the Granulocyte and RBC layers (please refer to Figure 3 for a visual guide). Manually rotate the QBC tube using the tube closure to examine the entire circumference of the tube. From here, examine the tube toward the closure end of the tube. Once you have reached the end of the tube, return to and scan the

buffy coat, where some of the more mature malaria lifeforms can be found. An experienced technician should be able to perform a QBC Malaria Test in approximately 3 minutes.

Figure 3

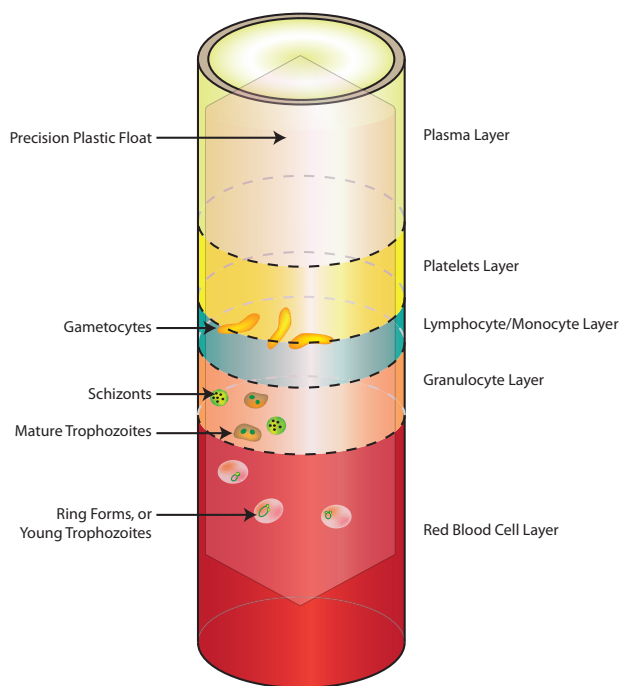

Cutaway Diagram of the QBC Malaria Test with Falciparum Malaria Parasites

Malaria parasites will often appear as young trophozoites, taking a signet ring shape. In the QBC Malaria Test, the “stone” of the ring will be green, while the “band” will be green to red-orange, and may or may not appear hollow. These ring forms are most easily found in the red blood cells near the granulocyte layer. Other signs possibly indicating the presence of malaria include yellow, sickle-shaped gametocytes (usually seen in *plasmodium falciparum* malaria); dark brown malaria pigment in mature trophozoites; schizonts; and gametocytes and distinct merozoites in mature schizonts.

Diagnosing Specific Forms of Malaria

Plasmodium falciparum – Falciparum malaria (seen in Figure 4) is the most deadly and most common cause of malaria. Falciparum malaria can infect all stages of RBCs and, therefore, typically will be distributed equally throughout the packed RBC layer. Some other common features that can help to distinguish *P. falciparum* parasites from other parasites include:

- Greater ratios of immature trophozoites to mature trophozoites and schizonts

- Double infections, i.e. two trophozoites in one RBC
- Headphone shaped trophozoites
- Yellow-green crescent, or sausage-shaped, gametocytes
- Equal distribution of ring forms throughout the RBC layer

Plasmodium vivax – Vivax malaria (seen in Figure 5) attack reticulocytes, which represent a small portion of blood cells (normally < 0.7%). These parasites will usually be found predominantly in the top of the packed red blood cell layer. Some common features that distinguish vivax parasites from other parasites include:

- Smaller ratio of immature trophozoites to mature trophozoites and schizonts
- Single, ring shaped infections
- Round gametocytes
- Schizont merozoite count of 7 to 12

The ParaLens can also be used to diagnose other, less common forms of malaria, such as *P. Ovale* and *P. Malariae*. Both forms exhibit characteristics similar to Vivax Malaria in the QBC tube. If Ovale or Malariae are known to be endemic to the area, additional testing may be indicated for samples that exhibit Vivax characteristics.

Other Suggestions

We recommend that any technician unaccustomed to the ParaLens or the QBC Malaria Test should first view several blood samples that are negative for malaria. This will allow the viewer to better understand what healthy blood looks like under the ParaLens and in the QBC tube as well as to help identify common staining artifacts.

Fresh blood samples should always be used, if possible. Store unanalyzed blood specimens at 2 to 8°C (35 to 46°F).

Conclusion

An experienced microscopist can effectively use the ParaLens Microscope Attachment and QBC Malaria Test to provide accurate diagnosis in the treatment of malaria. The ParaLens technology, with its unique LED light source, can turn any light microscope into a powerful fluorescence microscope at a minimum of cost or burden. Thus, the ParaLens and QBC Malaria Test can serve as important tools in the worldwide battle against malaria.

Figure 4

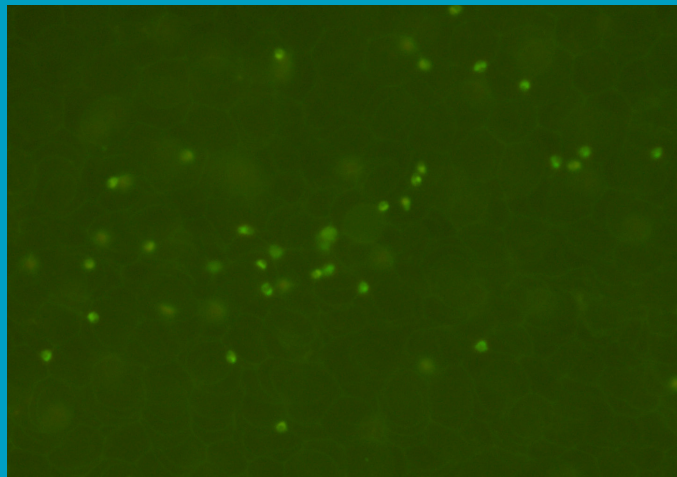

Falciparum Rings in the RBC Layer

Figure 5

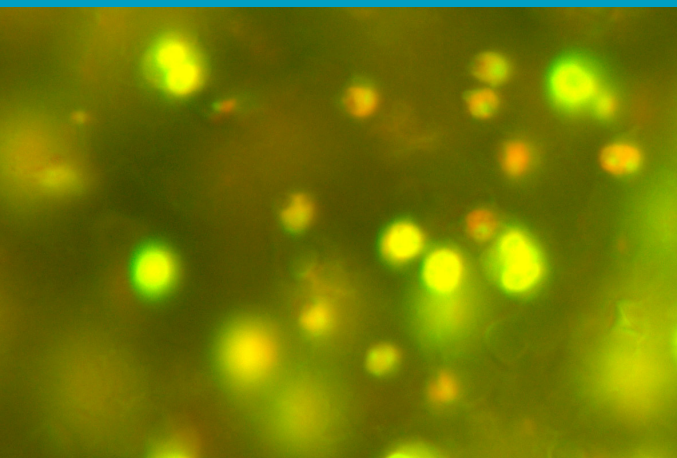

Vivax trophozoites in white blood cell layer

References

1. Centers for Disease Control Website. Centers for Disease Control, 2009. Web. 3 Sep. 2009. (www.cdc.gov/malaria)
2. World Health Organization Website, 2005. Web. 3 Sep. 2009. (<http://www.who.int/mediacentre/factsheets/fs094/en/index.html>)
3. Shute, G., Sodeman, T.: Identification of Malaria Parasites by Fluorescent Microscopy and Acridene Orange Staining. Bull. Wld. Hlth. Org.: 1973, 48, 591-596.